

Track Lighting in Museums

Part 2: Lighting Control

by Bob Herskovitz and Rich Rummel

Recap

In Part 1 of this article (Interpreter, November–December 2006), we discussed the damaging effects of light on museum collections, explained why track lighting is a good choice for museum exhibits and described the steps for selecting a museum-quality track lighting system.

In Part 2 we'll talk about how to control lighting in museum exhibits. The aim: to minimize exposure of artifacts to light without compromising viewing conditions for the museum visitor.

Quantifying light exposure

To gauge the effect of light exposure on museum artifacts and to evaluate various means of mitigating that exposure, you must know how to quantify the amount of visible light to which an artifact is subjected. That exposure can be calculated in units of lux-hours. Using a light meter, first determine the intensity of the light in units of lux. (If your meter measures in foot-candles, multiply the reading by 10 to get the equivalent in lux.) Then multiply that figure by the duration of exposure, measured in hours. For example, an item exposed to 50 lux for seven hours gets 350 lux-hours of light exposure.

Let's say your museum is open six days a week for seven hours a day, 52 weeks a year. And let's say that the light illuminating that wedding dress in your permanent exhibit measures 200 lux. Assuming that the light remains on during museum hours, in one year the



Fig. 1: Among components of a system to reduce the intensity and duration of light on sensitive artifacts are (top row) dimmer switches and (bottom row) occupancy sensors with power pack.

dress would receive 436,800 lux-hours of exposure to light (200 lux x 42 hours x 52 weeks). That's almost nine times the annual exposure of 50,000 lux-hours recommended for light-sensitive materials such as textiles, paper and photos (a figure derived from the textbook ideal of 50 lux x 1,000 hours of exposure).

Strategies for light control

Controlling museum lighting means limiting the total exposure of objects to levels of light acceptable for both artifact preservation and visitor comfort. Part 1 of this Tech Talk expounded the benefits of using track lighting systems: they come in a variety of fixtures and lamps to suit a wide

range of applications; they can be used to highlight discrete areas of an exhibit; and they are flexible, making lighting changes easy as exhibits change.

There are other key ways to regulate the amount of light on objects while they're on exhibit – reduce light duration, and reduce intensity.

The intensity of visible light can be reduced by any of the following means:

- Use lower-wattage bulbs or fewer lights.
- Move the light source farther from the object on display.
- Deflect daylight with window shades or blinds.
- Install neutral-density filters on fixtures.
- Use dimmer switches (see page 5).

Photos by Eric Mortenson



Figs. 2 and 3: In a two-circuit track lighting system with an occupancy sensor on only one circuit, the circuit without sensor provides a constant level of light. You may choose a combination of minimal lighting on sensitive artifacts with bright light for nonsensitive areas (left) or a uniformly low level of light throughout (right).

Reducing the duration of light exposure is probably the most beneficial and cost-effective measure you can take to minimize its damaging effects. Among the strategies you might use:

- Exhibit items for a shorter time.
- Close curtains, blinds or shades to block outside light when the museum is closed.
- Turn off lights manually when there is no one in the exhibit gallery.
- Use occupancy sensors (motion detectors).

Occupancy sensors

An occupancy sensor (fig. 1) – an automated method of reducing the duration of exposure – turns lights on and off in response to motion detected. When a sensor detects visitors in the monitored area, lights are switched on via a power pack, a device containing both the power supply and a relay switch. When visitors leave, lights switch off after a user-defined time delay.

For purposes of this discussion on how to set up occupancy sensors, we'll assume you are installing a two-circuit track system with a sensor on only one circuit – a configuration that meets the needs of most small museums. In one possible scenario, the circuit without the sensor can be set to provide constant, relatively bright lighting on labels, interactive stations and nonsensitive artifacts but minimal lighting on light-sensitive objects (see fig. 2). In another scenario, that circuit can be set to provide a uniformly low level of light throughout the gallery (fig. 3). When motion is detected, the second circuit comes on to provide additional light at a level sufficient for viewing all objects comfortably (figs. 4 and 5).

To suit a variety of applications, occupancy sensors come with a range of sensing fields – wide angle, round, spot and narrow curtain. Manufacturers have excellent technical support services to help you determine the best

sensor for your situation. For a list of manufacturers, go to www.mnhs.org/techtalkresources.

How much difference can an occupancy sensor make? Let's go back to that wedding dress in your exhibit gallery. If the lights were on only when someone was actually looking at the dress (hypothetically, an average of twice an hour during museum hours for six minutes at a time), the light exposure on the garment for the whole year would total 87,360 lux-hours – a reduction of 80 percent. If the light level was lowered from 200 to 150 lux, the annual exposure would drop to 65,520 lux-hours – close to the textbook ideal of 50,000 lux-hours.

Installing the equipment

Installing occupancy sensors is surprisingly simple. Start by deciding what areas of your museum you want to control. The exact number and size of those areas will vary with the layout of your exhibition. However, it is recommended that you have at least two



Figs. 4 and 5: When an occupancy sensor detects motion in the exhibit gallery, lights on the second circuit of the two-circuit system come on to boost lighting to a level sufficient for viewing all objects comfortably.

control zones. A front-and-rear or side-to-side arrangement is the easiest to manage. Consider creating additional spot zones for prominent or particularly sensitive artifacts in the exhibit.

Fig. 6 illustrates the configuration of components needed for the system. Work with a qualified electrician to install the power pack and sensors, using this diagram to guide the installation. The lighting track in the drawing has two circuits, only one of which is controlled by the motion sensor. This is the circuit for light fixtures aimed at the sensitive artifacts. The other circuit is for lights on labels and graphics and for ambient light in the gallery. Ambient light keeps the exhibit space from being too dark and seeming “off limits” to museum visitors.

Work with the installer to determine the best location for the sensors. Start with recommendations from the manufacturer; sensors work best when placed so that the visitor’s path crosses

the lens of the sensor rather than coming directly toward it. Then adjust the direction and spread of the sensor based on a “walk test,” moving through the exhibit as you expect visitors to do. Make sure that the sensor detects visitors in time for the light to come up as they arrive at the artifacts in question.

The cost for a sensor and power pack is approximately \$100 – \$150. Depending on your layout and the ease of both access to the wiring and placement of sensors in the appropriate location, it should take an electrician 4 to 8 hours to install the equipment for an existing track lighting system. Labor for installing these components as part of a new system would add little to the cost of wiring and installing the tracks.

Dimmers

Dimmer switches (fig. 1) will add flexibility to your museum lighting system, allowing you to adjust the intensity of the lights. No longer will you be limited to standard bulb

wattages. With dimmers, you can fine tune the amount of light in any given area of your exhibit. If, for example, a 50-watt flood on an object is inadequate but a 100-watt flood sheds too much light, a dimmer switch allows you to turn the intensity of the 100-watt bulb down to the equivalent of a 65- or 70-watt bulb. Using a light meter together with dimmers, you can ensure that an object will be visible to viewers but will not receive more light than is needed. Such a system will contribute significantly to the long-term preservation of sensitive artifacts.

Fig. 6 shows where the dimmer is located in the lighting circuit. High-quality dimmer switches typically cost between \$50 and \$100 each – a small price to pay for the benefits received.

One word of caution: Avoid cheap dimmers from home improvement stores; they’re designed for residential applications, not museums. A list of suggested manufacturers for

museum-grade dimmers can be found at www.mnhs.org/techtalkresources.

You will need to decide where in your museum to locate the dimmer switches. There are two options: you may simply change out the wall switches in your exhibit gallery for the dimmers, or you may choose to locate the dimmers in an area not accessible to the public (the additional wiring for this will require some additional expense).

Filters

The last item on the list of control measures is UV filters. Because the entire spectrum of UV light falls outside the visible range of light, it can be filtered without affecting the visibility of objects on display.

UV filters come in various forms:

- Film, commonly applied to windows.
- Plastic diffusers for fluorescent fixtures.
- Sleeves that go over fluorescent bulbs. (Both hard and soft sleeves are available; more-durable hard sleeves can be reused after changing bulbs.)
- Glass filters for track lighting fixtures.

When selecting a filter, it is important to choose a product that filters 99 percent of the entire spectrum of UV light. The full range of ultraviolet light that affects collections starts at approximately 300 nanometers (nm) and goes to 400 nm. Some products on the market advertise that they filter 99 percent of UV light without noting that they filter only up to a frequency, or

wavelength, of 380 nm. Ask for product specifications before you buy.

A list of vendors can be found at www.mnhs.org/techtalkresources.

Summing it up

Controlling light with the use of track lighting, motion detectors, dimmers and filters is one of the most effective, efficient and cost-effective methods of protecting the condition of your museum collections. There are other benefits as well. Equipment costs are modest. Bulb life can be extended, significantly reducing energy consumption. And because installing the equipment has to be done only once at the beginning of an exhibit, there is no ongoing cost in staff time. In fact, there is a net savings in staff time for long-term exhibits since the need to rotate light-sensitive items is reduced or even eliminated. To top it off, your exhibit lighting will be more dramatic.

In sum, there is no downside – collections are better preserved, operating costs are lower, staff time is reduced and the look of your exhibits is improved.

If you have questions about this Tech Talk on track lighting systems or wish to discuss a particular application, please call the MHS Conservation Outreach Program at 651-297-1867 or 1-800-657-3773; fax 651-296-9961; or email conservationhelp@mnhs.org. ■

Tech Talk offers technical assistance on conservation, historic preservation and museum management issues that affect historical organizations and museums of all sizes. This Tech Talk comes from Bob Herskovitz, outreach conservator for the Minnesota Historical Society, and Rich Rummel, the Society's lighting designer for exhibits.

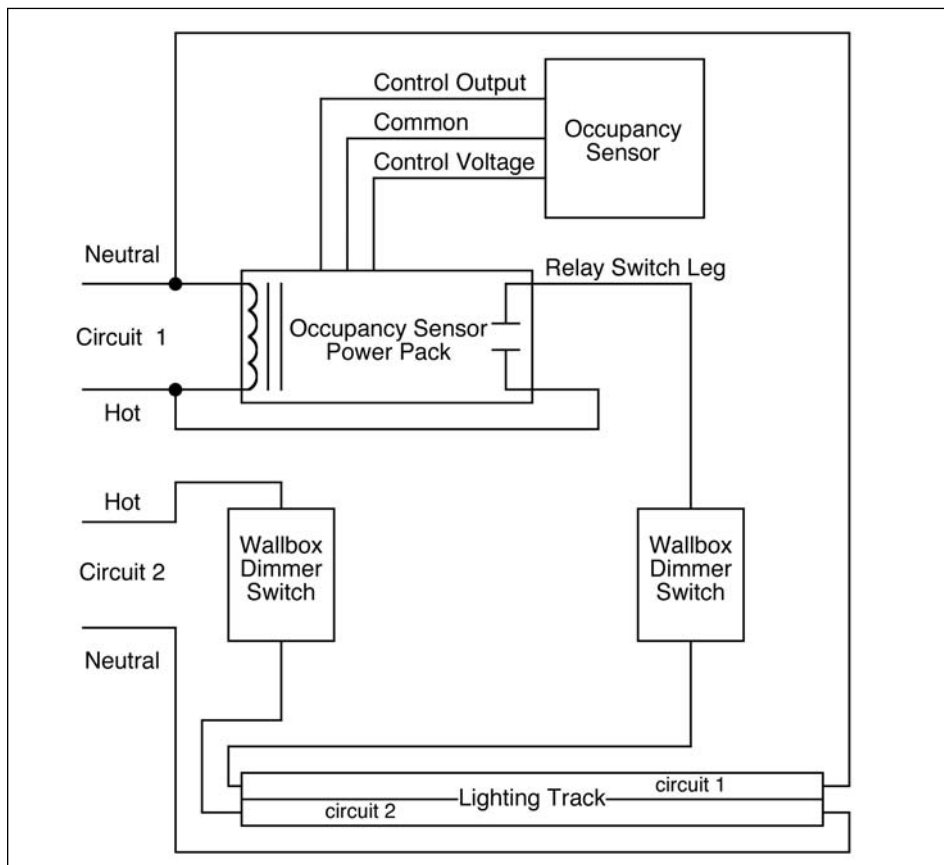

Fig. 6: Configuration for a two-circuit lighting track controlled by an occupancy sensor.